

analogue  
tube

# AT-4 $\beta$ (Beta) Mono tube mic pre

User Manual

Serial No \_\_\_\_\_

# analogue tube

Thank you for purchasing the AT-4 $\beta$ . The design of the AT-4 $\beta$  Beta is a unique design using common tube designs of the 1950s. Unlike the AT-3 the AT-4 $\beta$  Beta implements negative feed-back to improve stability when amplifying.

The AT-4 $\beta$  Beta is a tube Mic/Line/DI preamp is a traditional 3 stage circuit design that uses feed-back positioned between V1 and V2. Feed-back is used to help increase amplifying linearity and performance as well as lower distortion. For this type of design there is a slight increase in amplification over the AT-3 before saturation providing a super clean low noise output.

The audio transformers and onboard micro relays are the same as the AT-3 for this traditional pre amp design to achieve a clean tonal balance for all inputs with the shortest possible signal path used in today's modern recording. The mic input features a custom switchable 600/150z hi/low impedance transformer using specially selected low noise 7025 triodes for a better than -55db THD+n.

A standard non inductive carbon composition gain control adjusts volume level smoothly between each half section of V1 and V2 of the 7025 triodes to drive a cathode follower output stage into the LL1940 output transformer delivering clean gain at the output.

The AT-4 $\beta$  has 3 inputs: Mic, Line and DI input switching onboard micro relays switching for the cleanest path signal path.

The DI button over-rides both balanced inputs and accepts a 1/4" unbalanced mono jack at -20dbu instrument level straight into the front end of the 7025 input for a super clean ultra wide 60khz broadband output. Phantom switches the 48v in with a slow rise time. The power supply is all linear with an adjustable and regulated heater power up. B+ supply: linear.

## Audio transformers

- Mic IN Custom Sowter TX (high-low z)
- Line IN Lundhal LL1935
- Line OUT Lundhal LL1940

The AT-4 $\beta$  Mic input transformer is a customised Sowter type and has a high low Z input: 600 $\Omega$  or 150 $\Omega$

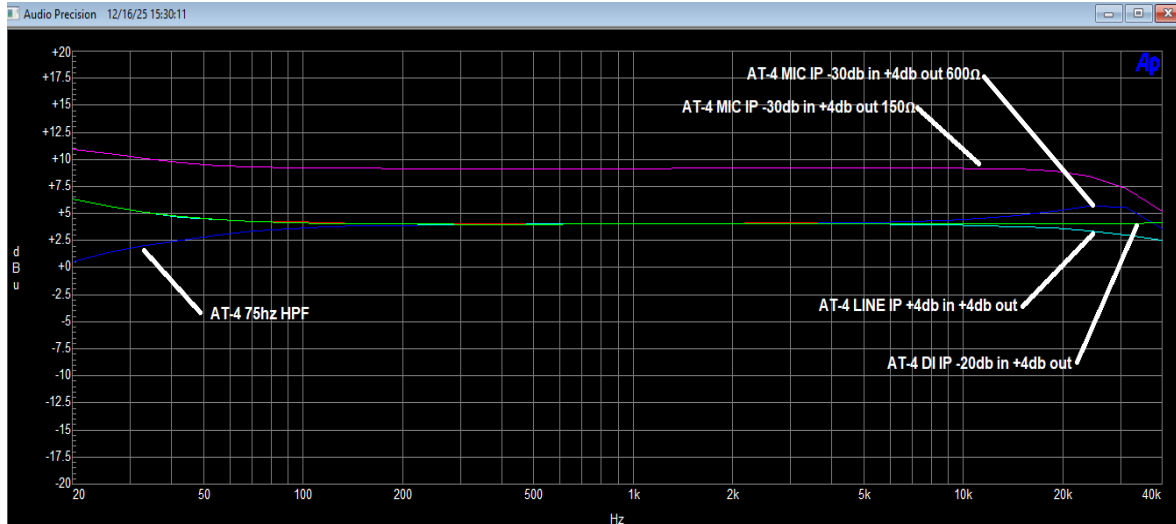

fig 1

In addition to the above features, the AT-4 Beta has a switched balanced line input giving you a program dependant HF tilt which is great for tonal applications adding colour and texture to your program when the Line input is driven. This is done using a combination of gain adjustment and input level. When Line IN is selected you simply drive the input level whilst decreasing the gain control to maintain an output level +4dbu when running your unprocessed dynamic music into the unit. Whilst the gain in its self is not high (around 7dbu) the user can drive the input stage up to +20 dbu helping to gently flatten out and extend the HF beyond the 50khz region for an ultra wide frequency response.

### Line input Set-up

Select line input, feed in a +4dbu program line level then adjust the gain control to pos 7 or unity output for +4dbu. Followed by feeding in a +10dbu signal level and decrease the AT-4 gain control again for an approximate +4dbu output level and so on.

To experiment more; feed in a +16dbu signal backing off further the gain control to an approximate +4dbu output followed by +20dbu signal each time backing off to an approx +4dbu output. With unprocessed music program this maybe a little be a little tricky to do at first so a little experimentation may be needed. The HF tilt range is measured at the 20khz region but will extend flat beyond 50khz.

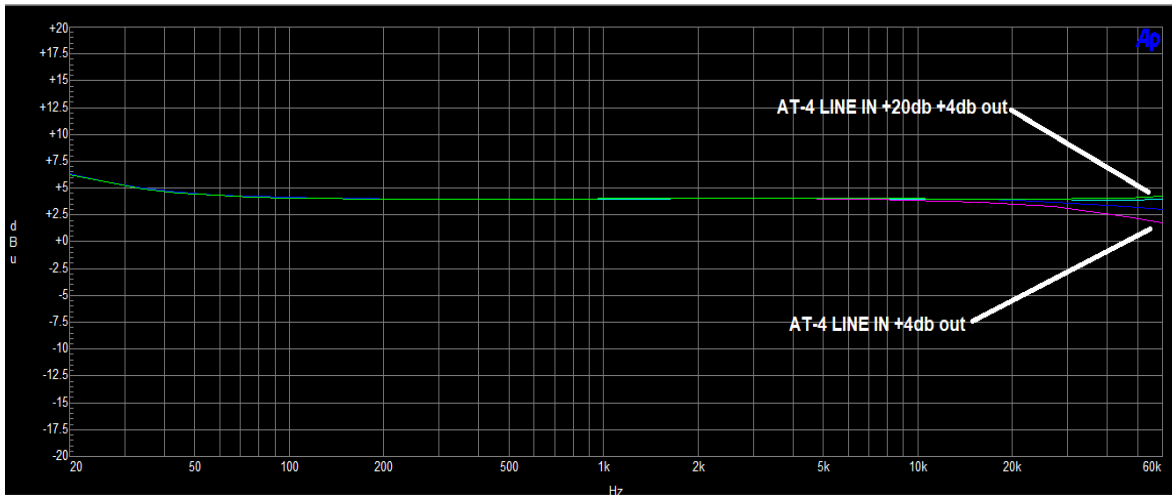
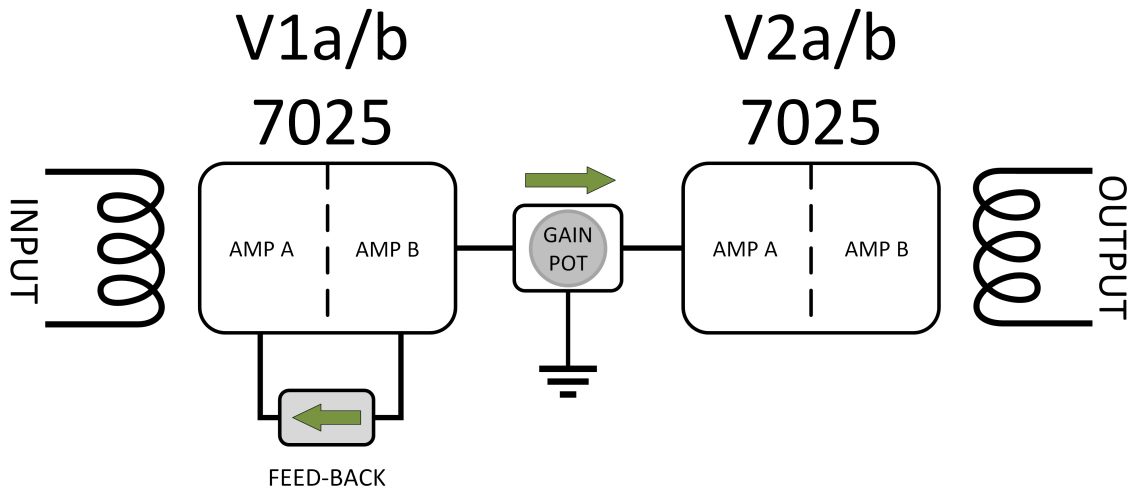

fig 2

## AT-4 BETA SIGNAL FLOW



# analogue tube

## SPECIFICATIONS

Mic Input	Balanced Hi/Low Z
Mic Input impedance	150/10K or 600/10K
Mic input gain (conservatively rated)	Approx 45db with a -30db input with a better than -60db THD+n output
Mic input pad	15db
Max line input level	Balanced 20dbu headroom
Line input gain (conservatively rated)	7db gain with a +4db input Unity gain with a +4db input with a better than -45db THD+n output.
DI i/p	High Z unbalanced
DI input gain (conservatively rated)	30db of gain with a -20db input with a better than -45db THD+n output.
High pass filter	75hz (internally adjustable)
Frequency response	20hz to 20khz <0.5 db
XLR in and out	Pin 2 Hot
Dimensions	Dims: H90 x W216 x D420 2u half 19" width space
Power	120/240v 50/60hz 20w IEC fused 350ma
Weight	Approximately 7kg.
Tube complement	1x 7025 input tube V1 1x 7025 output tube V2
Power Supply	Linear
Fuse type:	500 mA T Glass Cartridge Fuse, 5 x 20 mm T= TIMED/SLOW BLOW
Dims H90xW216xD300	2u half 19" width space.

# analogue tube

Racking kit available for mounting 2 units side by side into 19" rack slot

## Looking after your AT-4β

Your AT-4β tube mic pre amplifier should give you many years of uninterrupted service when observing the following simple guidelines:

### Operational Guidance.

- Do not move the unit whilst ON
- Do not move the unit whilst hot
- Do not operate in small un-ventilated spaces
- Allow the unit to cool down before moving
- Allow free cool air to flow over unit when ON
- Operate at the correct voltage!
- Always fit correct tubes to your unit 7025 or equivalent
- Always switch unit OFF when not in use

### Tube changing

There are many versions of the 7025 tube with substitutes widely available. You can easily experiment with changing the colour and tone of your unit by substituting tube types. Designations include: ECC83, 12AX7, ECC83S. Manufacturers (but not restricted to) include Electro Harmonix, JJ Electronics, Harma, Mullard, Mazda

### Additional information

Your choice of mics: The AT-4β has been tested with a broad range of microphones, here is the list so far..

AKG 414B p48  
Neumann U87 p58  
Neumann U87 Ai  
Neumann Fet 47  
Neumann Kmi84  
Lucas CS-1  
Wunder U47  
Royer 121 ribbon  
Neumann M49  
Geffen cardioid



Safety first!

The AT-4 $\beta$  is conservatively rated but like all tube equipment is subject to heat, please be aware that your unit will become warm during operation. Additionally extremely high voltages and potentials are present inside this equipment, no attempt should be made to adjust the unit internally without the help of a properly qualified service engineer. If in the unlikely event adjustments need to be made please contact [simon@analoguetube.com](mailto:simon@analoguetube.com) first.